

MODE

INSTALLATION / SERVICE INSTRUCTIONS

KS1150 Peninsula 400

Gas Fireplace

Important:

The appliance shall be installed in accordance with;

- This installation instruction booklet
- Local gas fitting regulations
- Municipal building codes
- Electrical wiring regulations
- Any other relevant statutory regulations.
- AS/NZS 5601.1 Gas Installations

NOTE: NOT INTENDED FOR FIREPLACE INSERT

**WARNING:**

This appliance must be installed by a qualified person. **This appliance must be installed into a cavity strictly in accordance with the following instructions.**

DO NOT SPRAY AEROSOLS IN THE VICINITY OF THIS APPLIANCE WHILE IT IS IN OPERATION.

DO NOT USE OR STORE FLAMMABLE MATERIALS IN OR NEAR THIS APPLIANCE.

DO NOT PLACE ARTICLES ON OR AGAINST THIS APPLIANCE.

DO NOT MODIFY THIS APPLIANCE.

This appliance is not intended for use by young children or infirm persons unless they have been adequately supervised by a responsible person to ensure that they can use the appliance safely. Young children should be supervised to ensure that they do not play with the appliance. Failure to follow these instructions could cause a malfunction of the heater, which could result in death, serious bodily injury, and/or property damage. Failure to follow these instructions may also void your fire insurance and/or warranty.

Who can install this product:

Installation must be carried out by a registered installer who, on completion of the installation, must issue a:

AUS: Certificate of Compliance

NZ: Certificates that comply with the latest legislation in accordance with national and/or local codes.

If these are not issued then the Escea warranty may be void.

Warranty Repair and Annual Servicing:

Please contact Escea if you require warranty work. Warranty repair work must be carried out by a recognised gas fire technician. It is recommended that recognised Escea Gas Fire Technicians are also used to carry out annual servicing requirements (particularly during the warranty period). For contact details of recognised Escea Gas Fire Technicians in your area, or for replacement parts, please contact the retailer from whom the appliance was purchased or visit our website.

The heater must be installed according to these instructions and in compliance with all relevant building, gas fitting, electrical and other statutory regulations (eg. AS/NZS 5601). Any shortcomings in the appliance and flue installation will be the responsibility of the installer, and Escea will not be accountable for any such failings or their consequences.

Manufactured by: Escea Ltd, PO Box 5277 Dunedin NZ, Ph: +64 3 478 8220

For contact details of your local Escea distributor or dealer please visit www.escea.com or email: info@escea.com. From Australia, visit www.escea.com.au or call: WA : 1-800 730 140;

EA : 1-800 460 832

KS1150 Peninsula 400 PRODUCT SPECIFICATION

MODEL NAME		KS1150 Peninsula 400		
Description of Appliance		Indoor Gas Fire Heater		
Star Rating		3.4 Stars		
Max Heat Output		6.6 kW		
AS/NZ Approval Standard		AS/NZS 5263.1.3		
Gas Type		Natural Gas	Propane	ULPG
Gas input	High	33 MJ/h	33 MJ/h	33 MJ/hr
	Low	24 MJ/h	24 MJ/h	24 MJ/hr
Inlet Pressure	Max	5.0 kPa	5.0 kPa	5.0 kPa
	Min	1.13 kPa	2.75 kPa	2.75 kPa
Operating Pressure on High		0.74 kPa	1.5 kPa	1.5 kPa
Operating Pressure on Low		0.34 kPa	0.76 kPa	0.76 kPa
Burner Jet Size		LH & RH: 1.50mm Middle: 1.95mm	LH & RH: 0.95 mm Middle: 1.25mm	LH & RH: 0.95mm Middle: 1.25mm
Burner Aeration		LH & RH: Closed Collars Middle: Closed Collar	LH & RH: 2 x 6mm Middle: Spacer (no restriction)	LH & RH: 2 x 6mm Middle: Spacer (no restriction)
Pilot injector		#42	#27	#27
Appliance Dimensions (mm)	Width	350 mm		
	Height	790 mm		
	Depth	1270 mm		
Weight	Kg	140 kg		
Ignition System		Electronic Ignition to pilot system Escea PCB		
Ignition Activation		20 secs (approx)		
Flame Safeguard		Flame Rectification		
Consumption		160W @ 0.69A 230V		
Remote controls		Yes		
Timers		Yes		
Clock		Yes		
Function lock / child		Yes		
Temperature control		Yes		
Connections	Electric	230V AC		
	Gas	1/2" BSPT female lower centre of fireplace chassis		
	Flue Type	Aluminium Flexi Flue and PolyPro		
	Flue Size	75mm and 100mm Flexi Flue		
	Spigot Location	Top RH Side		
Data badge location		On Chassis Base		

A	Product Description and Dimensions	6
A1	Product Description	6
A2	Product Dimensions	6
B	Creating the Cavity	8
B1	Cavity Shape	8
B2	Designing the Cavity	8
B3	Hearth	9
B4	Cavity Base	9
B5	Wall Linings	9
B6	Television & Mantel Clearances	9
C	Installing the Flue	10
C1	Flue Configuration (If less than 8m flue length is required)	10
C2	Flue Configuration (If more than 8m flue length is required)	11
C3	Installing the Horizontal Powerflue Wall Terminal Option	12
C4	Installing the Internal Vertical Powerflue (UVP)	15
C5	Installing the External Vertical Powerflue (UVP)	17
C6	Installing in Accordance with Relevant Codes	18
C7	Running the Flue	19
C8	Running the Powerflue Electrical Cable	20
D	Installing the Electricity and Gas to the Appliance	21
D1	Power Supply	21
D2	Network Cable	21
D3	Gas Pipe Sizing	22
D4	Gas Pipe Position	22
D5	Gas Isolating Valve	23
E	Installing the Appliance	24
E1	Connecting the Flue	24
E2	Installation	24
E3	Removing (and Replacing) the Glass	24
E4	Remove the Infill & Burners	25
E5	Gas Type Conversion	25
E6	Operating the Appliance	27
E7	Checking the Gas Operating Pressure	27
E8	Remote Pairing Button	30
E9	Home Automation Setup	31

F	Finishing the Installation	33
F1	Gem/Crystalight or Coal Fuelbed Installation	33
F2	Log and Woodland Log Fuelbed Retainer Setup	33
F3	Log Fuelbed Installation	34
F4	Woodland Fuelbed Installation	35
F5	Flame Picture	36
F6	Wall Linings	37
F7	Locating Wall Mount Cradle for Wireless Control	38
F8	Operating the Appliance	39
F9	Normal Operating Sounds and Smells	40
G	Installation Checklist	41
S	Service Manual	42
S1	Annual Service Procedure	42
S2	Error Codes	43
S3	Cleaning the Fuel bed and Glass	45
S4	Checking Operating Pressure	45
S5	Replacing a Remote Control	45
S6	Replacing the Burners	46
S7	Serial Number	46
S8	Removing or Cleaning Fan	46
S9	Removing the Control Tray	47
S10	Pressure Switch Removal	47
S11	Replacing the Thermal Cut Out (TCO)	50
S12	Servicing the Horizontal/Universal Vertical Powerflue	51
S13	Wiring Diagram	52

A Product Description and Dimensions

A1 Product Description

The Mode KS1150 Peninsula 400 gas fire is an indoor room sealed gas appliance designed to be built into a false self-supporting cavity. It is a powerful gas heater that, on the lowest setting (effect only) will still generate approximately 50% heat. The appliance is flued using co-linear flexible aluminium flue. The user will control their fire with the Radio Frequency (RF) remote that will normally be located in its wall mount cradle. In addition to the RF remote the appliance has a single auxiliary On/Off button on the unit. When not in operation it is in a standby mode unless it is physically isolated from the mains supply.

A2 Product Dimensions

NOT TO BE MISTAKEN FOR CAVITY DIMENSIONS.

All dimensions are in mm.

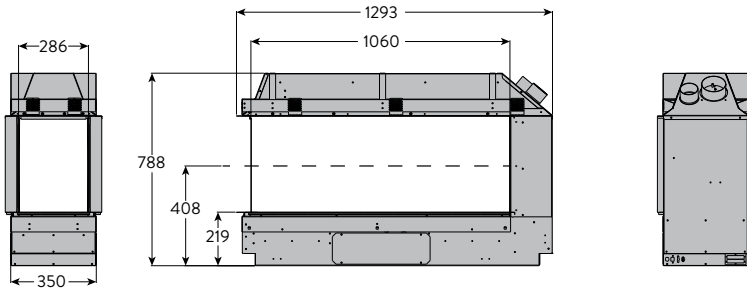

For more detail, contact the Escea architectural advisory team
Email : aa@escea.com

Important: Installations that are not specifically outlined in this manual should be referred to the Escea Architectural Advisory Team.

Please email aa@escea.com

A

B

C

D

E

F

G

SERVICE

Non-standard installations or scenarios not covered in this manual (including but not limited to sealed cavities, under bench installations, a recessed fire, or with overhangs protruding above the fire), can expose materials to higher than anticipated levels of heat.

While non-standard scenarios may meet the surface temperature combustibility requirements of AS/NZS5601 Gas Installations, some materials may be exposed to higher or undesirable levels of heat, or levels of heat greater than their tolerances allow. Specifiers and installers must choose materials when in these scenarios that meet the combustibility requirements AND the maximum service temperatures allowed by the chosen product. Escea takes no responsibility for material choice and reference should always be made to the relevant material manufacturer's maximum service temperatures for the suitability of use.

Please refer to the D-Series Gas Fire Materials Guide.

For more information on materials selection and for further guidance please contact our Architectural Advisory Team - aa@escea.com

To ensure that your installation is fully complete, please use the "Installation Checklist" on page 41.

Note : Keep this wooden support in place until install has been completed.

**ENSURE WOODEN SUPPORT IS REMOVED
ONCE FIRE IS INSTALLED**



A

B

C

D

E

F

G

SERVICE

B Creating the Cavity

B1 Cavity Shape

The KS1150 Peninsula 400 is suitable for self supporting timber/steel framed cavities. Most existing masonry cavities will not be suitable.

B2 Designing the Cavity

The following aspects must be considered when designing this installation:

- **Appliance is NOT load bearing**
- Appliance physical size
- Wall finishing and interaction with appliance
- Positioning of appliance in regards to wall lining (depth into wall)
- Exhaust termination aspect – horizontal / vertical and flue configuration
- Flue exhaust fan noise
- Exhaust cowl access for maintenance
- Gas pipe layout
- Gas isolation valve / pressure test point position
- Electrical isolation switch
- Home automation network connections - ethernet cable layout

This KS1150 Peninsula 400 fire is to be installed prior to any wall lining. The wall lining is the very last task to be completed in this installation.

The cavity and wall linings may be constructed from standard timber framing materials and do not need to be non-combustible.* SEE SECTION “Wall Linings” on page 37 FOR EXCEPTION.

Minimum Framing Dimensions

Note: Dimensions shown do not include allowances for clearance to combustibles to the flue.

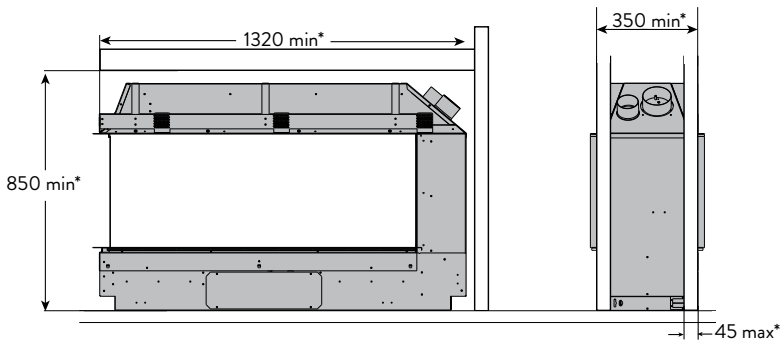

B3 Hearth

A hearth is not required. If a hearth is installed below the fire, it must be at least 100mm below the bottom of the glass or be composed entirely of non-combustible materials.

B4 Cavity Base

This appliance **MUST** be fully supported on its base, over the entire area of the underside of the appliance. The base must also be level and strong enough to support the total product weight, which is approximately **150kg**.

The fireplace can be recessed into the ground but must maintain the clearances detailed in the diagram (shown right) for any combustible flooring materials.



B5 Wall Linings

Only after all applicable sections up to section “Flame Picture” on page 36 have been completed, can you commence with the final wall linings detailed in section “Wall Linings” on page 37.

Wall lining cutout dimensions around the glass must be adhered to.

Please refer to section “Wall Linings” on page 37 for wall finishing dimensions surrounding glass.

B6 Television & Mantel Clearances

Television

The diagram (shown right) shows the recommended minimum clearances for the location of any electrical equipment (such as Plasma TV, LCD TV or home theatre) above a KS1150P gas fire. A mantel/recess is not required to comply with our recommendation of TV installation.

Note: Dimensions from the top edge of the glass frame.

Note: The television clearance recommendations are to be treated as a suggestion of a suitable installation only. It is the responsibility of the end user to check the installation instructions of their electrical appliances to ensure that the location in relation to the gas fire is suitable. Escea in no way guarantees or takes responsibility that the recommended installation suggestion will be suitable for all electrical or home entertainment appliances.

Mantel

Please refer to the diagram (shown right). Mantels or protruding ledges above the heater must not be installed lower than the dimension shown.

Note: Dimension from the top edge of the glass frame.

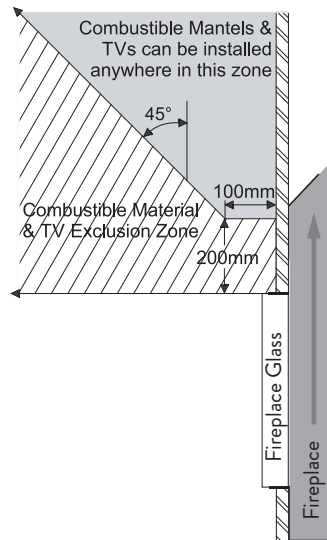

A
B
C
D
E
F
G
SERVICE

C Installing the Flue

C1 Flue Configuration (If less than 8m flue length is required)

If your flue system is less than 8m long (as shown in diagrams below), then a simple aluminium flexible flue is required. If you wish to install a longer flue run, then contact the Escea Advisory Team.

Horizontally Terminated: Utilises the Escea horizontal power flue enclosure kit.

The horizontal offset of the terminal can be any amount up to the total flue length listed below. Please consult with Escea's technical staff if your intended flue configuration falls outside of the bounds of the flue configurations shown below.

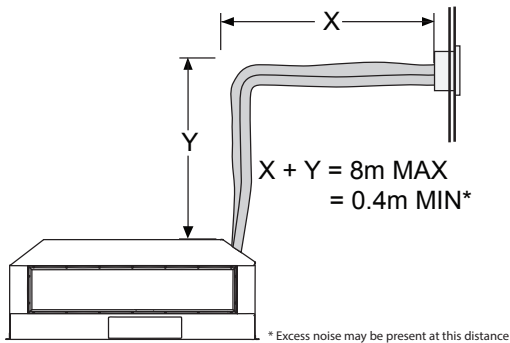

Note: When flueing above the fire, the pipe must slope towards fire - NOT towards the terminal. Also when flueing below the fire, the pipe must slope towards the terminal - NOT towards the fire.

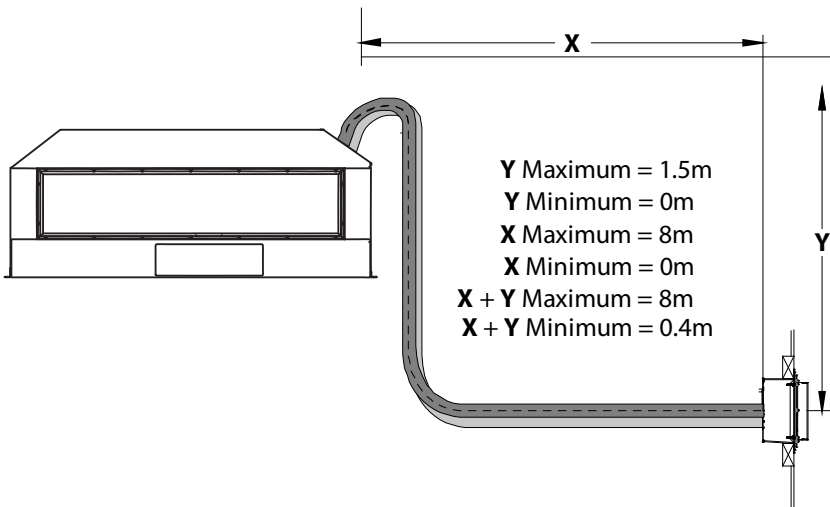

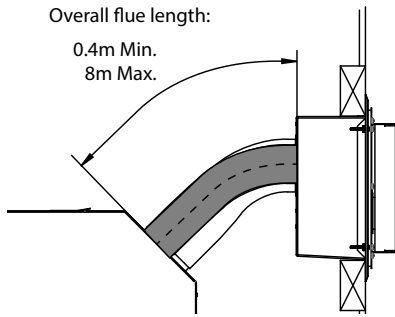

Vertically Terminated: Utilises the Escea universal vertical power flue enclosure kit.

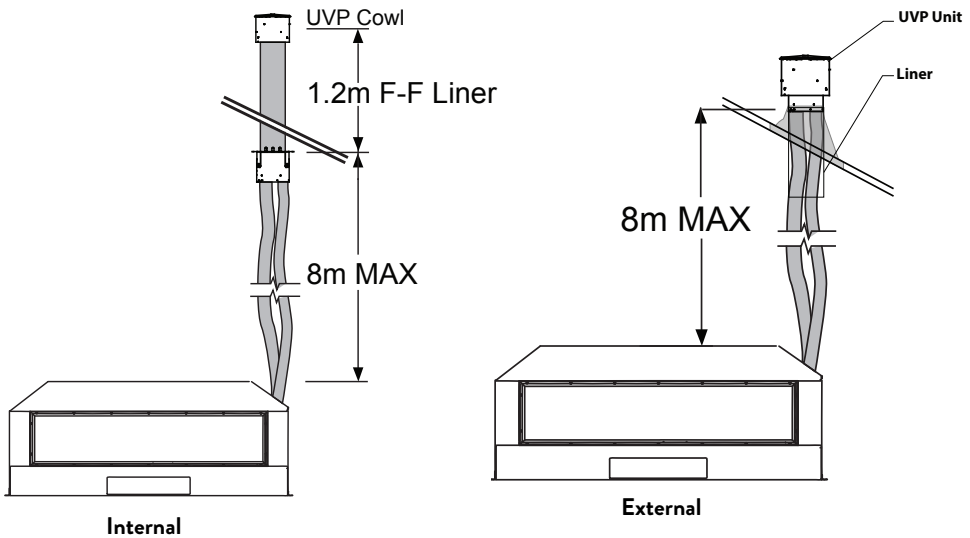

C2 Flue Configuration (If more than 8m flue length is required)

If your flue system is greater than 8m long (up to 40m long), then please contact the Escea Advisory Team at aa@escea.com for further guidelines.

C3 Installing the Horizontal Powerflue Wall Terminal Option

The horizontal powerflue wall terminal must be installed in the correct orientation (the small horizontal slot should be at the bottom). This allows for the correct operation of the flue system and prevents the ingress of water.

The horizontal powerflue wall terminal must be weather-tight when installation is complete to prevent damage to the dwelling. It must be installed by a suitably qualified person.

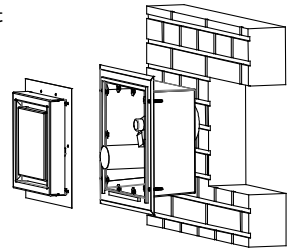

Fit the horizontal powerflue wall terminal into the hole and fix in place, making sure the installation is sealed appropriately to prevent the ingress of water from outside the wall cladding. Take notice of the label on the termination which shows the correct orientation of the terminal.

Note: It is the responsibility of the installer to ensure the horizontal powerflue wall terminal is installed to all relevant building codes to ensure weather tightness.

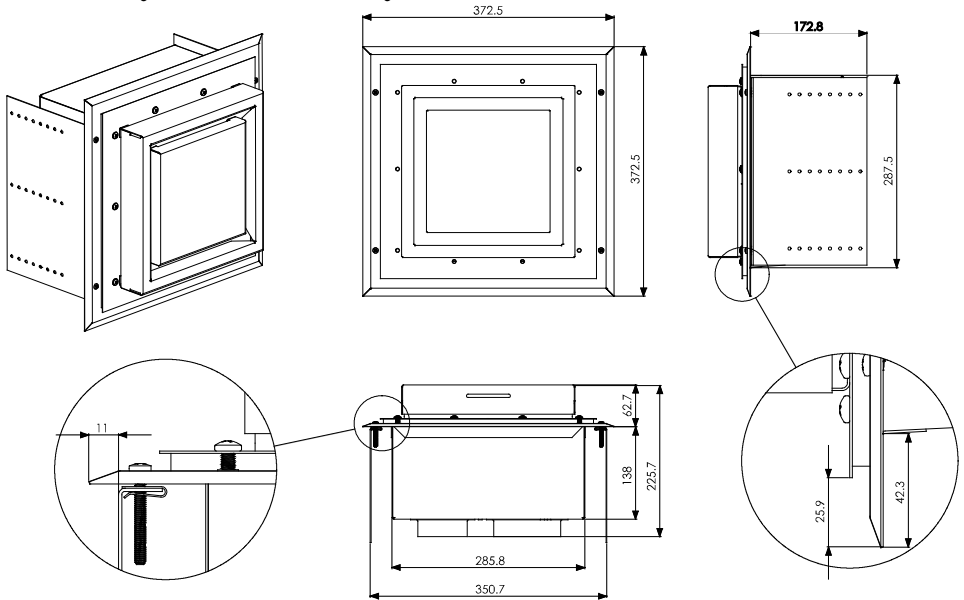

Creating the Hole in the Outside Wall

When cutting the hole in the outside wall, be mindful of how the installation of the horizontal powerflue wall terminal will be finished; the installation must be weatherproof.

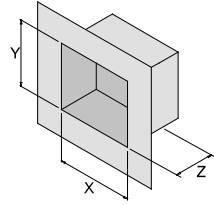

Ideal Hole/Cavity Size for Horizontal Powerflue		
	Without Side Brackets	With Side Brackets
X	298mm	360mm
Y	298mm	298mm
Z	175mm Excluding allowance for flue which exits here	

The horizontal powerflue wall terminal can be attached to the wall in two ways:

A) From the front of the terminal:

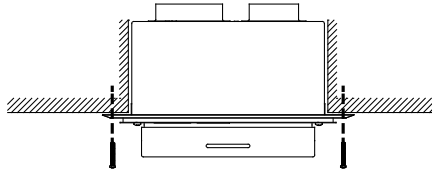

B) By attaching the optional wall terminal installation brackets to the sides of the cavity and attaching the horizontal powerflue wall terminal to these, from the front:

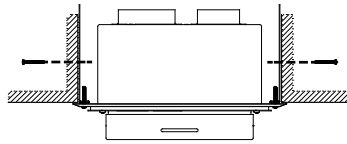

Attach the $\varnothing 100\text{mm}$ and $\varnothing 75\text{mm}$ flexible aluminium flues to the spigots on the rear of the horizontal powerflue wall terminal using the hose band clamps supplied. Plug the powerflue electrical cable into the back of the horizontal powerflue wall terminal.

Ensure that the electrical cable is firmly secured to the wall terminal or building to prevent damage or disconnection if pulled.

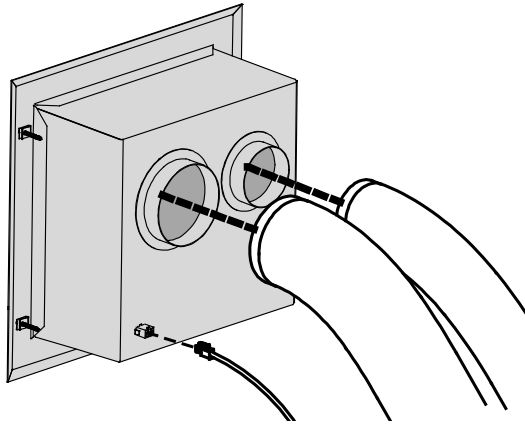

Fit the horizontal powerflue wall terminal into the hole and fix it in place, making sure the installation is sealed appropriately to prevent the ingress of water from outside the wall cladding.

Note: It is the responsibility of the installer to ensure the horizontal powerflue wall terminal is installed to all relevant building codes to ensure weather tightness. This may necessitate the use of appropriate flashing material where appropriate.

IMPORTANT: Ensure that flashings do not restrict the air intake slot around the periphery of the cowl.

How to Flash the Horizontal Powerflue

The following diagrams are excerpts from the Escea architect drawings and are available in full on our website. These diagrams are recommendations, and your installation must comply with any local or national building codes.

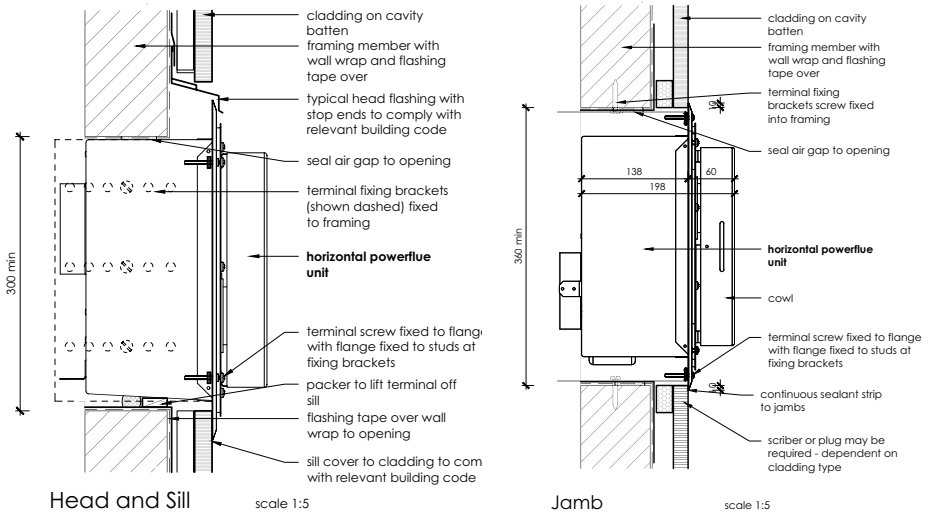

C4 Installing the Internal Vertical Powerflue (UVP)

Note: For information regarding an external install of the UVP, go to section "Installing the External Vertical Powerflue (UVP)" on page 17.

The Universal Vertical Powerflue (UVP) internal configuration is designed to have the fan, mounted within the roof space of the house, and the vertical Ø225mm diameter liner, containing a Ø100mm flexi, penetrate through the roof. The UVP internal conversion kit comes with a 1200mm liner that is specific to the internal installation and must always be used.

Note: The flue setup must comply with either section "Flue Configuration (If less than 8m flue length is required)" on page 10 or "Flue Configuration (If more than 8m flue length is required)" on page 11.

Use standard methods to flash the roof penetration. The installation must be weatherproof and conform to all local council standards including powered flue termination rules.

Mount the fan mount bracket (1) to the roof framing and strapping using timber ensuring that the flue is rigid and vertical. Ensure that the mounting timber does not obstruct access to the 3xM5 screw threads on the side of the fan unit.

Aim to have the fan enclosure (2) mounted as high as possible, mainly to allow sufficient fall for condensation drainage if the flexi-flue is to run horizontally.

Ensure there is sufficient space below fan enclosure (2) to have access to fit the flexi-flue tubes (3) and allow flowing bends if required.

Note: The UVP-Internal and the flexi flue connections must be installed in a location accessible for service or replacement; a service hatch or removable flashing to allow access may be required.

Note: When installing the unit onto a flue liner, ensure the length of flue liner above the roof is the minimum required length. **ENSURE** the Ø43mm restriction plate is installed on the inlet.

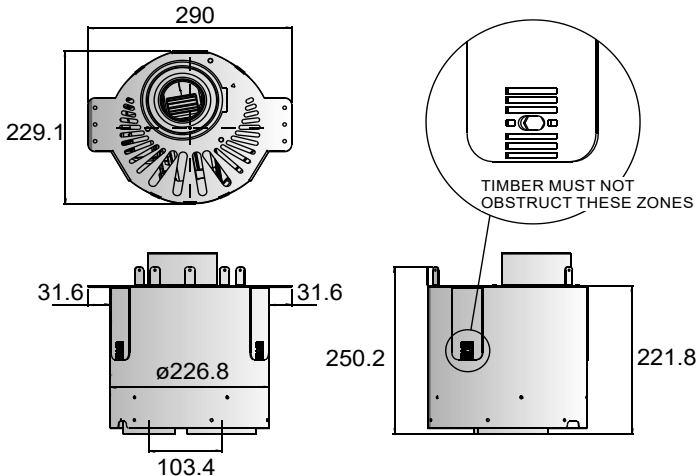
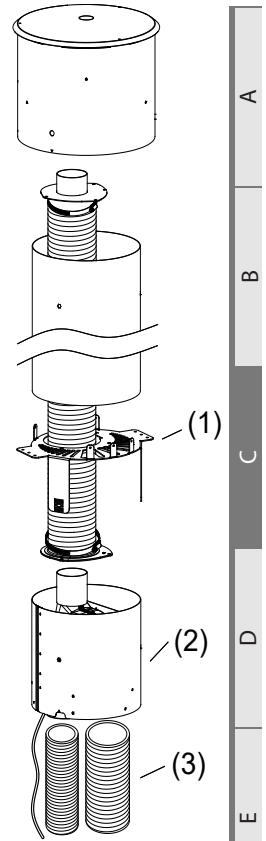

A
B
C
D
E
F
G
SERVICE

The UVP-Internal kit is intended for use within an accessible roof space or 'chimney' construction.
Service access must be provided.

Ensure installation complies with relevant building codes and regulations

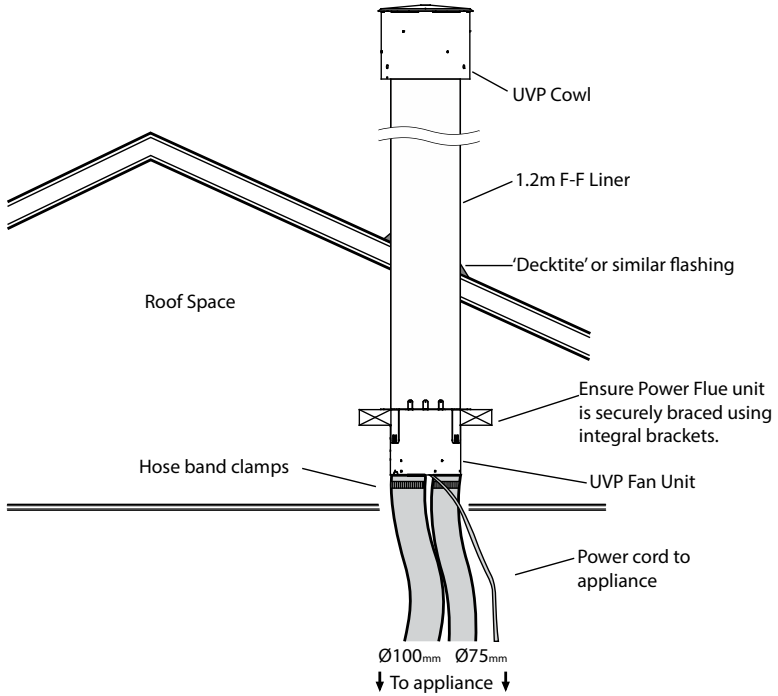

A

B

C

D

E

F

G

SERVICE

C5 Installing the External Vertical Powerflue (UVP)

Note: For information regarding an internal install of the UVP, go to section "Installing the Internal Vertical Powerflue (UVP)" on page 15.

The UVP is designed to have the enclosure containing the fan unit mounted externally; an example is shown below.

Note: When installing the unit onto a flue liner, ensure the length of flue liner above the roof is the minimum required length. ENSURE the $\text{\O}43\text{mm}$ restriction plate is installed on the inlet.

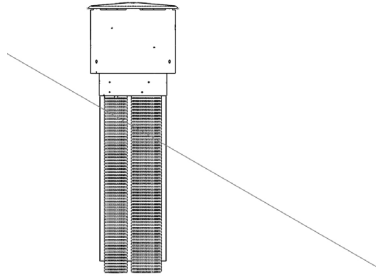

The cowl surround should be fixed in place as shown.

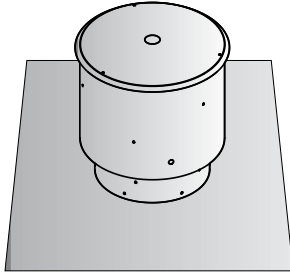

Mount the UVP kit to the top of a chimney flashing plate or penetrate the roof with an optional flue liner accessory and fit the UVP kit over the flue liner, sealing the penetration with a decktite or similar flashing. Ensure the terminal is vertical and rigidly mounted and the flexi flue attached below is fixed to the terminal spigots using the supplied hose clamps. The flexi flue is held in place by drilling 3 holes and screwing 3 self tapping screws evenly around each hose band clamp (as shown in the picture below).



C6 Installing in Accordance with Relevant Codes

The location of the horizontal powerflue wall terminal must be installed in accordance with AS/NZS 5601 and any other relevant building codes. If possible, avoid installing the horizontal powerflue wall terminal in areas exposed to high winds and extreme weather.

Some of the minimum clearances for a fan assisted wall terminal are listed below; please refer to AS/NZS 5601 Gas installation standard for full guidance on the design of the flue system. Where possible allow a greater clearance.

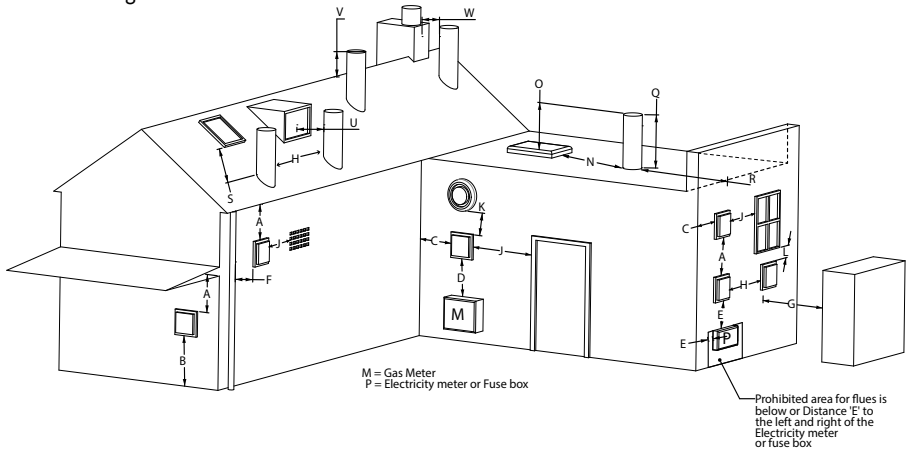

A	Below eaves, balconies and other projections	200mm
B	From the floor, above a balcony or other surface	300mm
C	From a return wall or external corner	300mm
D	From a gas meter or regulator vent	1000mm
E	From electricity meter or fuse box	500mm
F	From a drain pipe or soil stack	75mm
G	Horizontally from any building structure or obstruction	500mm
H	From any other flue terminal or combustion air intake	300mm
J	Horizontally from any moving window, door, non-mechanical air inlet, or any other opening into a building with the exception of sub floor ventilation	300mm
K	From a mechanical air inlet or spa blower	1000mm
L	Vertically below any moving window, door, non-mechanical air inlet, or any other opening into a building with the exception of sub floor ventilation	300mm
N	Horizontally from a roof light	600mm
O	Vertically from a roof light	500mm
Q	Vertically from a flat roof	500mm
R	Horizontally from a vertical structure	500mm
S	Below a roof window	2000mm
T	Above or either side of a roof window	600mm
U	From a dormer window	1500mm
V	Above the apex of the roof (see note 1 on following page)	300mm
W	From an open flue	1500mm

Notes:

- 1) Should the flue not extend past the apex, the bottom opening of the flue should extend at least 200mm from the roof (or 300mm in regions with heavy snow).
- 2) The installation of a flue into a carport is not recommended.
- 3) The flue terminal will get very hot when in use. Precautions should be taken to protect people and animals from injury.

C7 Running the Flue

A 50mm clearance to combustibles must be maintained from the exhaust flue for the first 1.5m of flexi flue from the appliance (see diagram below).

Run the $\varnothing 100\text{mm}$ and $\varnothing 75\text{mm}$ flexible aluminium hoses from the cavity to the rear of where the horizontal or vertical powerflue terminal will be installed. Allow enough stretch in the flexible aluminium flue to allow it to protrude through the wall/ceiling/roof/flue liner to enable it to be connected to the powerflue terminal. The flue should be expanded at each end in order for the flue to be attached to the fire/powerflue. It is advisable to secure the flexi flue at regular intervals to prevent vibration, movement and sagging. Steel wire or 'builders strapping' may be used for this purpose.

Note: The flexible flue is shipped in a 'compressed' form. Extend it to your desired length by stretching.

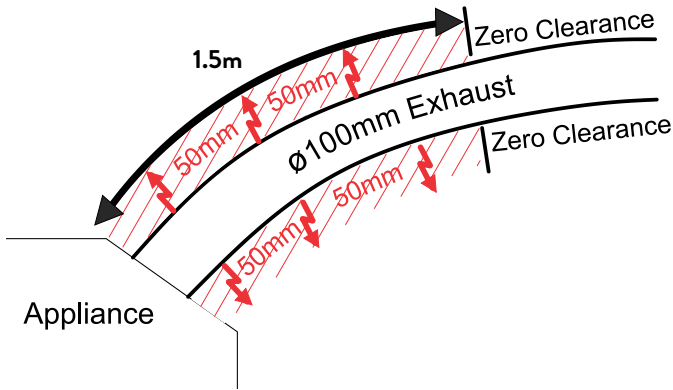

C8 Running the Powerflue Electrical Cable

Note: The powerflue terminal is powered from the appliance and must be connected to the appliance with the supplied electrical cable only.

Note: Ensure that the appliance power supply is disconnected before making the connection to the terminal

The supplied electrical cable is 7m long; flue extension kits also include a powerflue electrical cable extension.

Run the electrical cable from the cavity where the appliance will be installed to the hole in the outside wall. Ensure it is not draped over, or in contact with, the outer shell of the appliance or the flues.

The cable must be kept clear from any other possible heat sources, sharp edges, or moisture. Fix it appropriately and allow enough cable to be able to pull both the appliance and the powerflue terminal out from their installed positions.

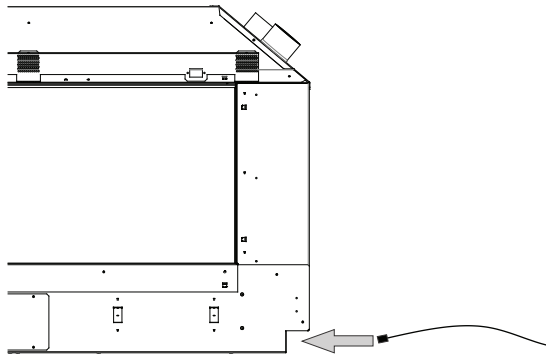

If you do not connect the powerflue electrical cable to both the fireplace and the powerflue, this will result in an error when the fireplace is turned on. Test the fan before continuing with the rest of the installation.

END OF SECTION C

By the end of this section, you should have:

- A weather-tight installed powerflue terminal with clearance as specified by AS/NZ5601
- Reasonable access to the terminal for maintenance purposes
- Flue attached to the powerflue terminal leading back to the appliance with the correct flue clearances
- The electrical cable from the powerflue terminal run back to the appliance cavity in an electrically safe manner

D Installing the Electricity and Gas to the Appliance

D1 Power Supply

While the cavity is being created, consideration must be given to the location of an appropriate power supply. An earthed 230/240 volt mains power connection (typically a standard 3 pin outlet) must be available within 1m of the bottom right of the appliance. This connection **must** be accessible after the heater has been fully installed so that the appliance can be safely disconnected from the mains power supply prior to servicing.

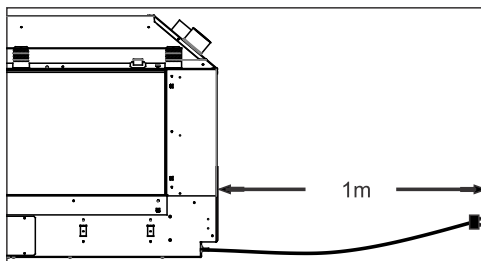

A mains isolation switch (compliant to AS:NZS 5601 Clause 6.2.8) which is accessible from outside the cavity can also be used to disconnect the power.

Regardless of the method used, it **MUST ALWAYS** be possible to safely isolate the electrical supply to the appliance after it has been fully installed.

This appliance must not be located immediately below a socket outlet. This appliance will draw a maximum of 2 Amps from a 230/240V supply. No additional power supply is required for the power flue.

D2 Network Cable

A 10 metre length of network (ethernet) cable has been supplied. Connect it to the appliance (lower right) and the buildings' modem.

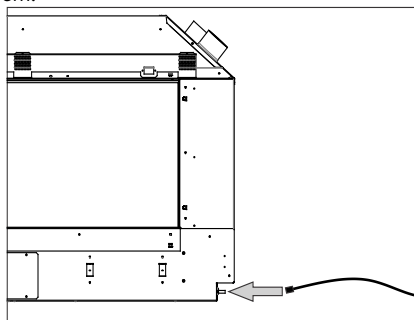

Two network cable access points are available: the primary connection is on the bottom of the RH outer face of the appliance for connecting permanently to the buildings' router; the secondary connection point is located where the AUX button is (shown in section "Remote Pairing Button" on page 30) for service technicians to access when the main connection method has not been used and has become inaccessible.

If you do not wish to connect the fireplace to the modem, the network/ ethernet cable should be run to somewhere accessible by a service technician, such as a cupboard.

D3 Gas Pipe Sizing

Gas pipe should be sized as per the requirements of AS/NZS 5601.1. The pipe sizing must be sufficient to deliver the following volume of gas to the heater with all other gas appliances in the home running at the same time:

Maximum KS1150 Peninsula 400 Gas Consumption = 33MJ/hr

D4 Gas Pipe Position

The gas connection is inside the appliance and is 1/2" male BSPT on the lower right of the appliance as shown below. Access is through the silicone grommet circled below on the RH side of the chassis.

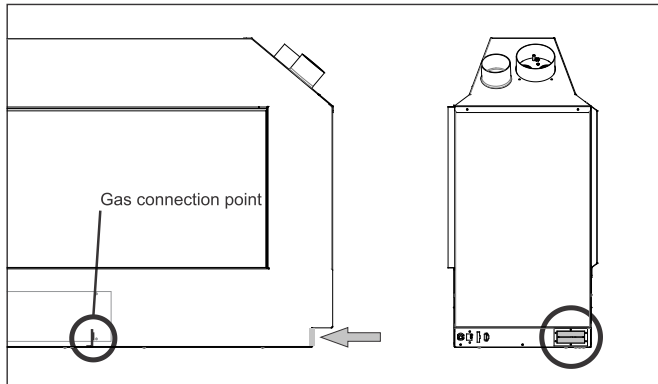

Access for connecting the gas supply to the gas connection point (shown in the diagram above) should be through the access hatches located on the front and back of the appliance (the front as shaded in the diagram below).

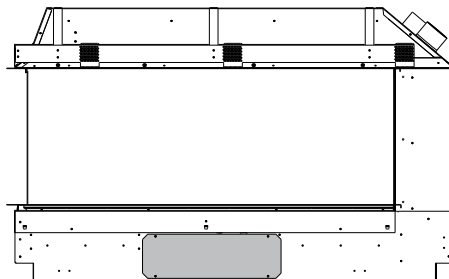

D5 Gas Isolating Valve

A gas isolating valve must be installed in the gas line as close to the appliance as possible. Fix it in a convenient position to allow it to be closed off quickly and easily during normal operation. Take into consideration access to this valve once the wall linings are on. This will also allow for easier servicing in the future.

A

B

C

D

E

F

G

SERVICE

END OF SECTION D

By the end of this section, you should have:

- An unlined cavity with 230/240V AC supply where the appliance can be plugged into an electrical isolating switch that is accessible once the appliance is installed
- A suitably sized gas supply to the right hand side of the appliance with a pressure test point, ready to be connected once installed
- Network cable installed, ready for plugging into appliance, regardless of being connected to Internet router/network

E Installing the Appliance

E1 Connecting the Flue

Access the top of the appliance and connect both the inlet flue (Ø75mm ID/85mm OD) and the exhaust flue (Ø100mm ID/110mm OD) to their respective spigots. Tighten the hose clamps onto the spigots. Ensure the flue connection is air tight. Sealant is not required.

WARNING: The flue connection **MUST** be secured with the clips provided and tape **MUST NOT BE USED**. If any of the flue pipe is damaged and integrity compromised then it should not be repaired with tape, it should be replaced.

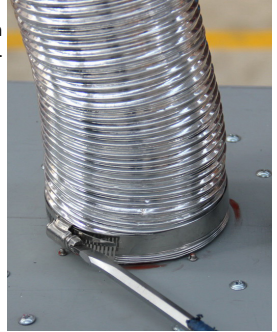

E2 Installation

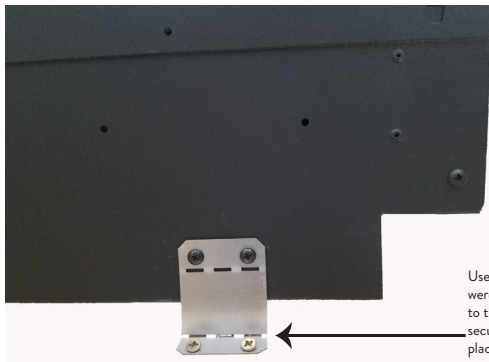

Use the brackets that were affixing the fire to the pallet for securing the fire in place once installed.

Insert the gas fire into the cavity and fix the appliance down in the correct position using the brackets on each end of the appliance.

It is a requirement that this appliance be securely fastened at the base.

Ensure that the fire is seismically restrained in a manner appropriate to the installation location.

E3 Removing (and Replacing) the Glass

Remove the glass by unscrewing the four 1/4 turn fasteners located at the top of the glass (shown in the diagram below) and remove the bracket (shown below shaded grey). Attach the provided suction cups and use them to handle the glass. Slide the glass away from the non-glass end. Allow the glass to lean towards you and carefully lift it out.

Place the glass carefully aside. Note that any soot on the glass can mark carpet and furnishings.

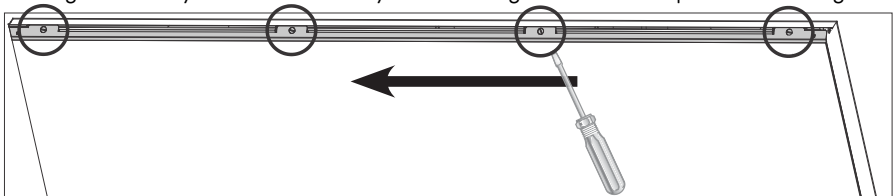

NOTE: When replacing the glass, check the channel that the glass sits in for debris that may be sitting on top of the fiberglass tape. Remove any debris prior to placing the glass. If you feel resistance when leaning the glass towards the fireplace, remove it and double check for debris in the glass channel.

WARNING: Trying to place the glass with debris in the glass channel may result in the glass breaking.

E4 Remove the Infill & Burners

Remove the four screws shown in the diagram below. Lift one end of the infill up into the top corner of the firebox and then out towards you, taking care not to scratch the firebox paint or the black glass. Remove the outer burners first by sliding them away from the centre of the fireplace, followed by the centre burner, which slides out to the left.

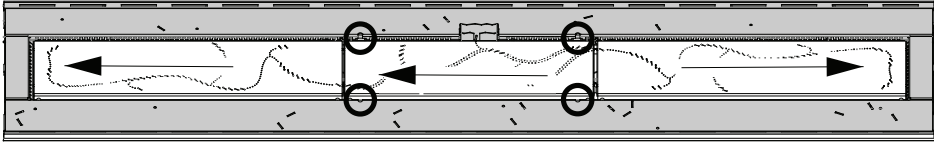

E5 Gas Type Conversion

THIS APPLIANCE IS CONFIGURED TO OPERATE ON NATURAL GAS, ULPG or PROPANE.

If gas type conversion is not required then skip to the next section.

If gas type conversion is required, please contact an Escea dealer to request the required parts. Follow the steps on the following pages to change from NG to ULPG/Propane or vice versa.

WARNING: The regulator that is supplied with the fire **MUST NOT BE REMOVED**. Removal of the regulator, or replacing it with one not intended for use with this Escea fire, will void the limited appliance warranty.

Turn off the power and gas first.

Step 1: Remove the 6 screws on the control tray hatch (shown shaded in the diagram below).

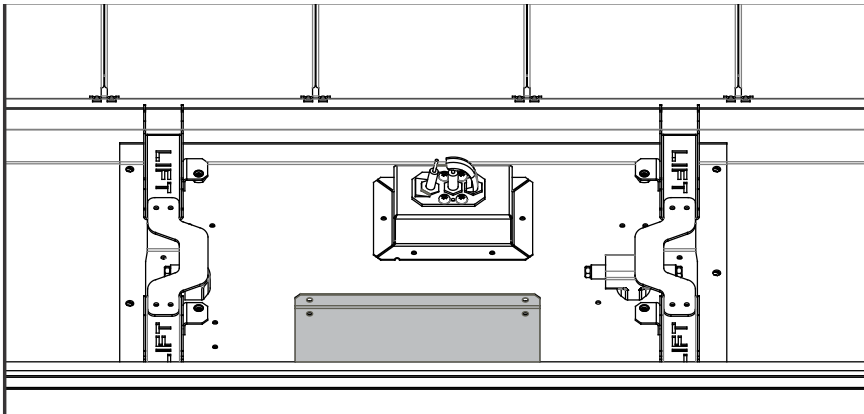

Remove the hatch to access the regulator and modulating valve below.

Step 2: Change the three main burner jets with the jets supplied in kitset (see tables on next pages).

Step 3: Replace the pilot jet (see tables on next page). Note: Ensure the pilot jet is joined up to the olive before inserting the jet into the pilot assembly (as shown below).

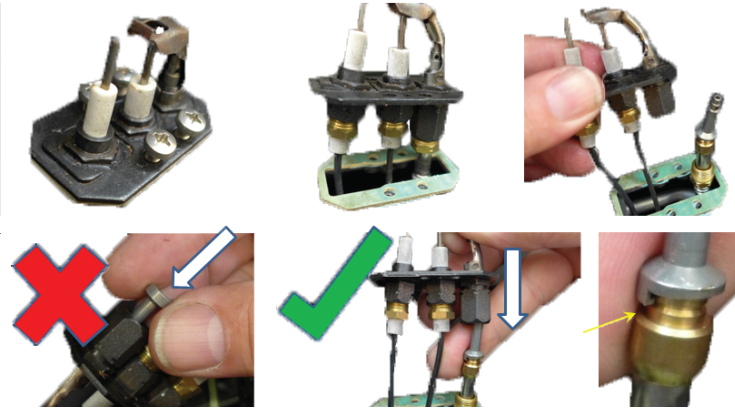

Step 4: Screw out the nylon adjuster screw inside the regulator to remove the existing spring. Replace the spring with the purple spring supplied in the conversion kit and reassemble the regulator.

Step 5: Stick the new gas type label supplied in the kitset on the underside of the tray hatch. Ensure the serial number and date of manufacture are still visible. Write your name, company (if appropriate) and date of conversion on the new label with permanent marker.

Step 6: Replace the hatch (removed in step 1). Take care not to over tighten screws.

Step 7: The burner tubes on the underside of all burners have convertible aeration collars. Ensure the aeration collars on all burners are correctly fitted on each burner tube.

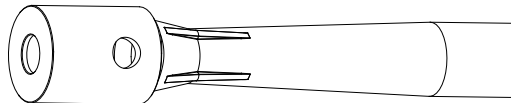

	Natural Gas					
	Burner Jets			Burner Collars		
	Middle Burner	Side Burners	Pilot	Middle Burner	Side Burners	
KS1150 Peninsula 400	Ø1.95mm	Ø1.50mm	#42	Fully Closed	Fully Closed	

	ULPG / Propane					
	Burner Jets			Burner Collars		
	Middle Burner	Side Burners	Pilot	Middle Burner	Side Burners	
KS1150 Peninsula 400	Ø1.25mm	Ø0.95mm	#27	Spacer	2 x Ø6mm Holes	

A
B
C
D
E
F
G
SERVICE

Step 8: Adjusting the electronic controller for gas type

Ensuring the gas is still OFF, Turn the power ON.

Insert "AA" size batteries into the remote control. You should now see the time on the display showing 0:00.

Press the MINUS, PLUS and FAN BOOST buttons simultaneously (as shown right) until the characters '03' light up on the display. Release the buttons and the remote will count down and display 'GO'. The screen will then display all characters. This will put the remote into test mode and the two big temperature digits should begin counting from 0 to 99 repeatedly.

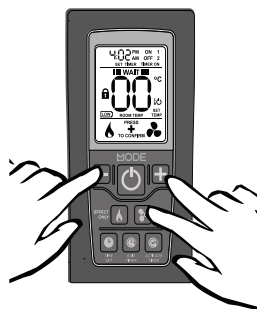

Now hold down the 'EDIT TIMER' and 'ACTIVATE TIMER' buttons simultaneously; the remote display will show the current configuration of either 'NG' for Natural Gas or 'LP' for ULPG/Propane. To change this configuration, hold down the 'EDIT TIMER' and 'ACTIVATE TIMER' buttons simultaneously for 5 seconds. This will now have toggled between gas types.

Once you have chosen the correct gas mode, press the '⏻' button once to exit the diagnostics mode.

E6 Operating the Appliance

Turn the fire on by pressing the '⏻' power button on the remote. Within a few seconds the appliance will begin its startup sequence with a 15 second purge of the flue fan. After the purge it will attempt ignition. It may take a few attempts to light the first time due to air in the gas line. You may wish to purge the gas line at the valve by bleeding the first test point. This requires a small blade screwdriver.

Once the fire has lit the pilot and main burner you will be able to measure the operating pressure. Set the remote temperature to 40 degrees Celsius by pressing the '+' button; ensure the remote is kept in a cool environment. This will allow maximum gas flow into the appliance.

Ensure all other gas appliances within the house are also operating at maximum.

If the operating pressure does not read within 5% of the table (shown on the next page) then remove the cap from the gas pressure regulator within the appliance and adjust the threaded spring stop. Press the '⏻' power button again to shut down the fire.

E7 Checking the Gas Operating Pressure

Note: Ensure the thermostat control within the remote does not cause the flame to modulate down by increasing the set temperature and keeping the remote in a cool environment.

Turn on the gas. Turn the power on.

Check the inlet pressure upstream of the appliance using the test point that you installed earlier.

Note: The regulator that is supplied with the fire MUST NOT BE REMOVED. Removal of the regulator, or replacing it with one not intended for use with an Escea fire, will void the limited appliance warranty and may be dangerous.

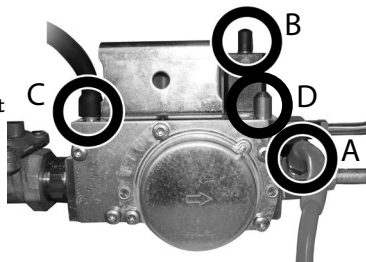

The gas valve (shown previous page) has manometer test points at A, C, and D. Ignore B.

Gas Pressure Table - KS1150 Peninsula 400	Gas Type		
	NG	ULPG	Propane
Minimum Inlet Pressure - Pre-Regulator	1.13 kPa	2.75 kPa	2.75 kPa
Maximum Inlet Pressure - Pre-Regulator	5.0 kPa	5.0 kPa	5.0 kPa
Operating pressure - Post-Regulator (Point C)	1.0 kPa	2.3 kPa	2.3 kPa
Operating Pressure when on high - (Point A or D)	0.74 kPa ±5%	1.5 kPa ±5%	1.5 kPa ±5%
Operating Pressure when on low - (Point A or D)	0.34 kPa ±5%	0.76 kPa ±5%	0.76 kPa ±5%

Remove the small access hatch found on top of the engine.

Loosen test point C (shown in the first diagram of this section) and attach a manometer tube in preparation for measuring the operating pressure—post regulator.

Turn the fire on high and adjust the operating pressure at the regulator (shaded grey in the diagram below).

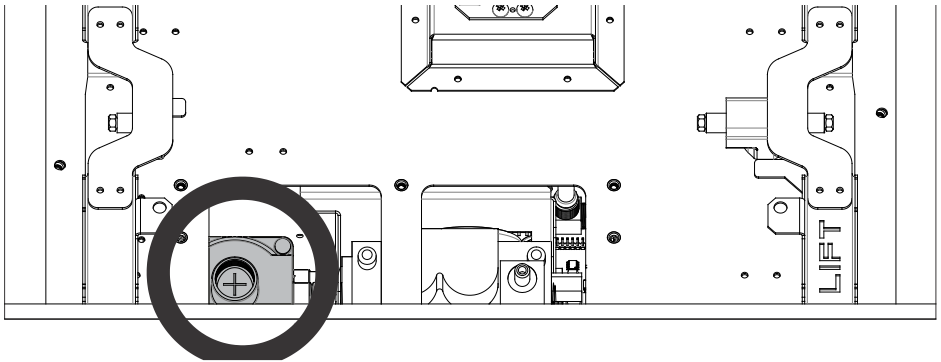

Once the operating pressure—post regulator—is set, check the operating pressure at test point A or D (shown in the first diagram of this section).

Changing the Operating Pressure from the Remote

The following instructions **must only be undertaken by a suitably approved person**. Any tampering by an unauthorised person will void the product's warranty and may result in a dangerous condition.

While the remote is in its 'OFF' mode with only the time showing on the display, press the MINUS, PLUS and FAN BOOST buttons simultaneously (as shown right) until the characters '03' light up on the display. Release the buttons and the remote will count down and display 'GO'. The screen will then display all characters and should be reading 00. This will put the remote into test mode.

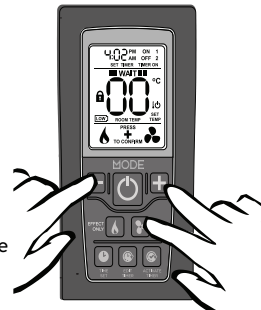

Whilst in test mode: press and hold the “ACTIVATE TIMER” and “FAN BOOST” buttons for 4 seconds to access the gas valve settings. The appliance will automatically turn on while in this mode.

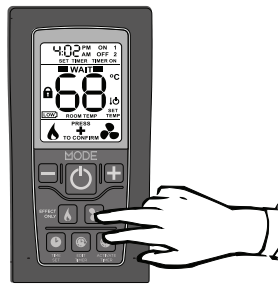

WAIT. Allow the appliance to fully light all burners before continuing.

The high setting for the currently set gas type is displayed first (indicated in the clock segments at the top). Pressing the plus or minus keys will change the setting up or down respectively, which will change the gas pressure measured at point A or D. The large digits will blink rapidly after the setting is made until the verification is received from the fire.

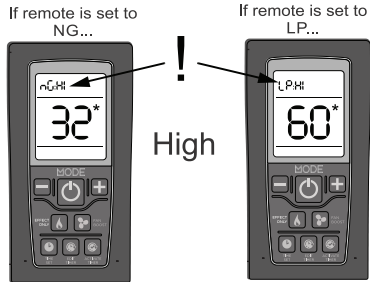

Note: The numbers displayed on the remote should only be used to achieve the correct pressure. The numbers by themselves do not represent anything and should not be relied upon.

Toggling to the low setting is done by pressing the ‘EFFECT ONLY’ button (indicated in the clock segments at the top and by the ‘EFFECT ONLY’ icon at the bottom). Settings are made with the ‘PLUS’ and ‘MINUS’ buttons as above. Exiting this mode is by pressing the on/off button.

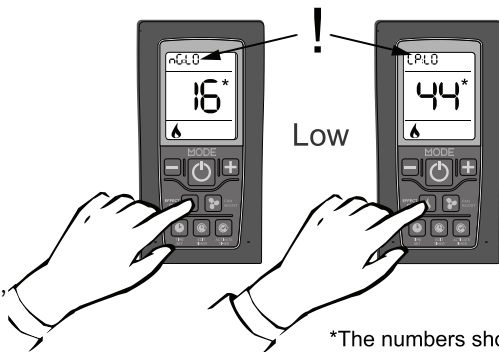

*The numbers shown above are not targets

Note: This is a powerful gas heater that, on the lowest setting (effect only), will still generate approximately 50% heat.

A
B
C
D
E
F
G
SERVICE

E8 Remote Pairing Button

The KS-Series fireplaces have a manual on/off button that should only be used for teaching the fireplace a new remote. The diagram below shows the location of this button. Section “Replacing a Remote Control” on page 45 of the service manual covers the steps necessary to pair a new remote.

Note: Ensure the appliance has cooled down before using the manual on/off button to avoid coming into contact with hot surfaces.

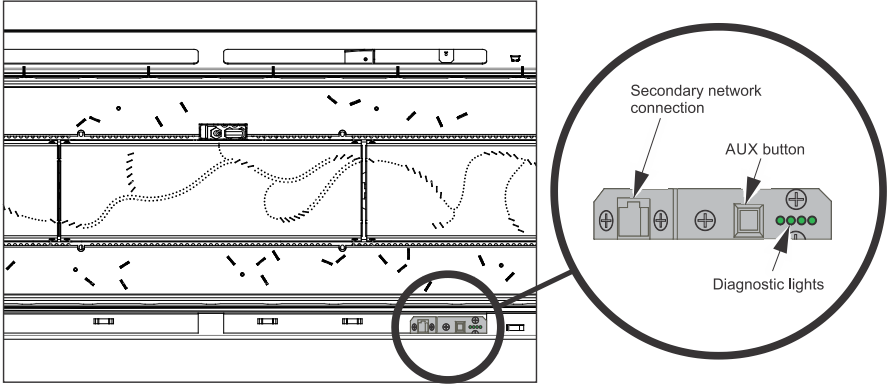

To access the auxiliary on/off button, remove the bottom trim bracket by lifting the bracket upwards (shown shaded below). Once both edges of the bracket are clear of the fire, slide the bracket towards the open end of the fire.

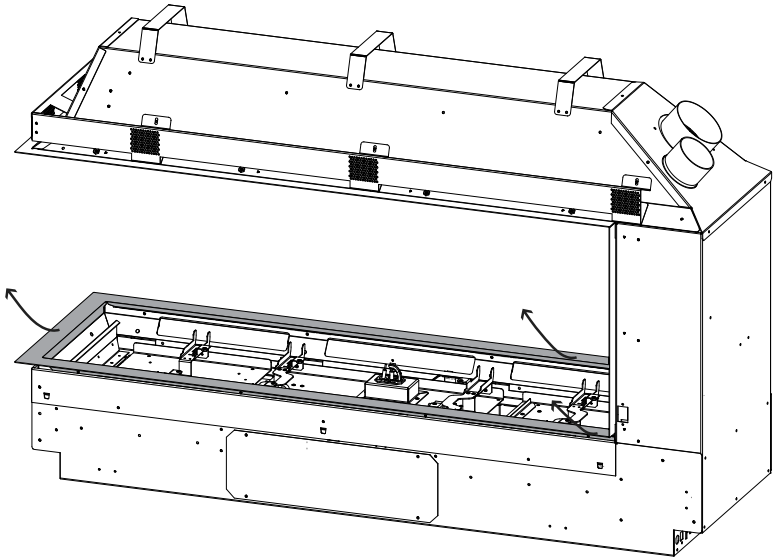

E9 Home Automation Setup

Escea K-Series fireplaces have a simple interface for connection to a home automation system. This allows the fireplace to be woken up, started, and then shut down. The “Close to Wake” connection (shown below) is essentially taking one of the 3.3 volt DC pins on the fireplace micro-controller and shorting it to ground.

In order to isolate the fireplace from the automation system, a relay needs to be used (as shown). This allows you to keep the fireplace’s 3.3V supply isolated.

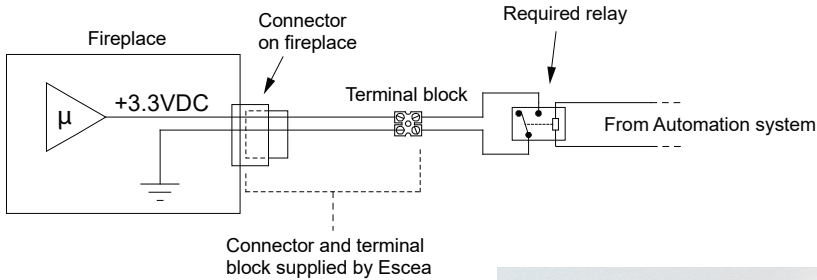

The home automation connection can be found in your fireplace accessory pack (shown right).

This connects to the fireplace via the lower RH outside panel of the fireplace, next to the primary network cable access point, as shown in section “Network Cable” on page 21.

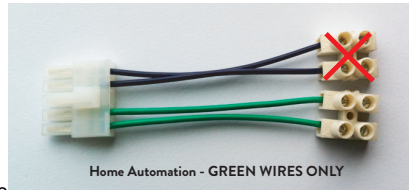

Home Automation Operation

Relay closed

The fireplace will start in a medium setting until the remote control talks to the fireplace and picks up the ‘ON’ signal (which can take up to 4 minutes). Once the remote has communicated with the fireplace it will turn on and begin operating thermostatically. The remote will use whatever temperature the user has previously set and cannot be altered by the home automation system. The fireplace will continue to operate while the relay is closed.

Note: If the fireplace cannot communicate with the remote within 10 minutes of the relay contact closure then the fireplace will shut down and return to standby. The remote controller is required to be within operating range of the fireplace for its safe operation.

Relay open

If the fireplace is operating with a closed relay then, upon opening the relay contacts, the fireplace will shut down and return the remote controller to its standby mode when it next updates (which can take up to 4 minutes). While the relay is open the fireplace will be in standby mode and available for manual operation by the user.

END OF SECTION E

By the end of this section, you should have:

- The appliance installed in the cavity
- The appliance fixed to the cavity base and wall lining
- The appliance plugged into a mains electricity supply
- The appliance gas supply attached and pressure tested with all other gas appliances running

F Finishing the Installation

F1 Gem/Crystalight or Coal Fuelbed Installation

If using the crystalight/gem or coal fuel beds, first place all the crystalight/gem or coal pieces in a single layer atop the burners and fuelbed tray. Cover the entire area except for the pilot shield, ensuring coverage right up to the edges of the firebox or glass.

Do not heap or mound any fuelbed.

F2 Log and Woodland Log Fuelbed Retainer Setup

When setting up a log or woodland log fuel bed, you must have the correct retainers present before assembling the fuel bed. The correct retainers are supplied with the fuel bed packaging. On your retainers you will see either a letter at the start that will determine the fuelbed type (i.e. W = Woodland, L = Logs). The letters and numbers that follow help to determine the retainer location.

Remove the infill by following section E4 on page 25. Place the infill upside down with the hole for the pilot on the side closest to you; this is the back. Remove the retainers from the flat nested sheet. When reading the text on each retainer, fold **ALL** the retainer tabs 90° away from you.

For some older infills, on the **UNDERSIDE** of the infill you may see numbers from 1 to 4. If the infill has numbers, then match the numbers on the infill with the numbers on the log retainers.

For all other infills, the combination of letters and numbers provides an indication of the location: B-Back, F- Front, L-Left, R-Right.

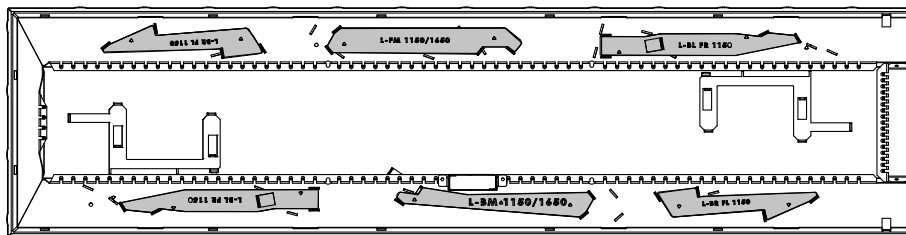

Attach all retainers by feeding the tabs from the **UNDERSIDE (unpainted side)** through the cutouts on the infill. Fix each retainer in place from the top of the infill with the screws provided.

Replace the infill and burners in the fireplace.

Only for the log fuelbed: the final log retainers are placed on **TOP** of the infill and burners to support the end log (number 2 from index). This part comes in flat form and is to be folded as per the images below.

They are then installed on both outer sides of the infill and are fixed in place by two screws as below.

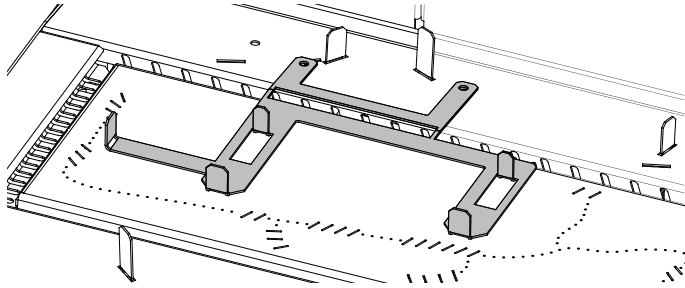

F3 Log Fuelbed Installation

Logs must be located correctly as stated/depicted in this section.

The final layout should replicate the picture shown in Step 3. Place the embers or flakes in a single even layer after the logs have been located correctly (excess embers or flakes should NOT be added if one even layer has been achieved). The embers or flakes must not cover the pilot or pilot guard.

Note: Improper positioning of any fuelbed media may create carbon build-up and will alter the unit's performance. Malfunctions due to improper fuel media placement will not be covered under warranty.

Log Index



	1	2	3	4	5	6	7
KS1150 Single/Double 850	1	2	2	2	2	0	2

Use the index above as a guide for selecting the correct logs.

Log Setup KS1150 Peninsula 400

Step 1:



Step 2:



Step 3:



F4 Woodland Fuelbed Installation

Logs must be located correctly as stated/depicted in this section.

The final layout should replicate the picture shown in Step 3. Place the flakes in a single even layer after the logs have been located correctly (excess flakes should NOT be added if one even layer has been achieved). The flakes must not cover the pilot or pilot guard.

Note: Improper positioning of any fuelbed media may create carbon build-up and will alter the unit's performance. Malfunctions due to improper fuel media placement will not be covered under warranty.

Woodland Log Index

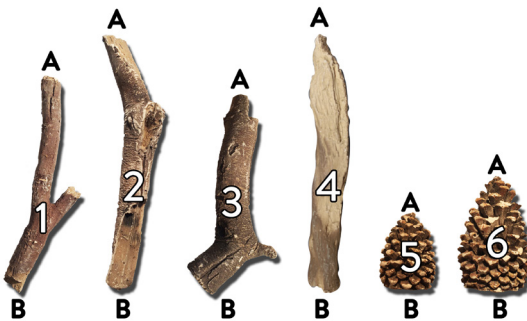

Use the index above as a guide for selecting the correct logs.

Woodland Log Setup KS1150 Peninsula 400

Step 1:



Step 2:



Step 3:



F5 Flame Picture

An abnormal flame pattern will look long and stringy; it may cause soot to build up inside the firebox.



An abnormal flame pattern will likely be the result of incorrect settings (jet size, burner aeration collar). Check that these are correct before proceeding. If an abnormal flame pattern is still present, please contact Escea.

It is the responsibility of the installer to ensure a correct flame pattern.

F6 Wall Linings

The final wall lining can only be commenced after all previous applicable sections have been completed. The appliance must be installed prior to and behind the finished wall surface. Allow clearance for any plasterboard, tiles, or other finishing materials that may be intended for the finished wall surface. The wall board that lines the outside of the opening can be normal plaster board and does not need to be non-combustible. The plasterboard is to protrude beyond framework as shown in the following diagram.

Note: The final wall lining must not encroach within the specified dimensions in this section. These dimensions indicate the opening required in the wall lining. Encroaching on the minimum cut out dimension may inhibit the future serviceability of the fire.

The glass viewing area of the fire is bordered by a black metal trim. This acts as a junction between any wall linings and the viewing area. Combustible wall linings must not exceed this dimension and protrude past the black trim. Failure to follow these instructions may risk damage to the adjacent wall lining. Wall linings should be cut to 6mm +/-2mm from the black reveal.

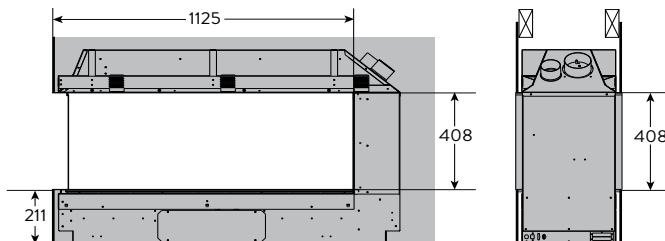

If the wall lining used protrudes past the top trim, non-combustible material **MUST** be used (see image below, dashed line represents edge of trim)



Note: The wall lining directly above the appliance will get warm and hence may discolour paint finishes that are susceptible to temperature damage. The heat may also distort vinyl wall coverings. For durability of finishes and surfaces you should contact the relevant manufacturer for their specification and avoid materials with temperature ratings not suitable for use above a fireplace (see section A2 on page 6).

A
B
C
D
E
F
G
SERVICE

The wall lining can be fixed to the gib fixing bracket (circled below). There are eight areas on the bracket (five circled below and three more on the opposite side) that can be used for fixing screws.

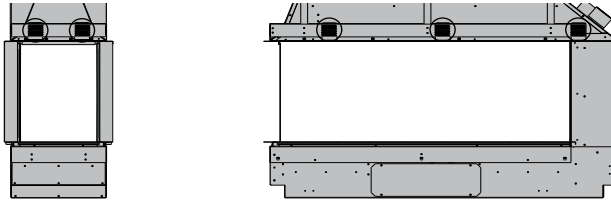

Frameless

The KS1150 Peninsula is a frameless fire. It is necessary to ensure that the edge of the wall lining is finished in a tidy manner (for a nice Gib finish we recommend Gib Rondo stopping bead). Please allow a clearance of 6mm +/-2mm around the black reveal.

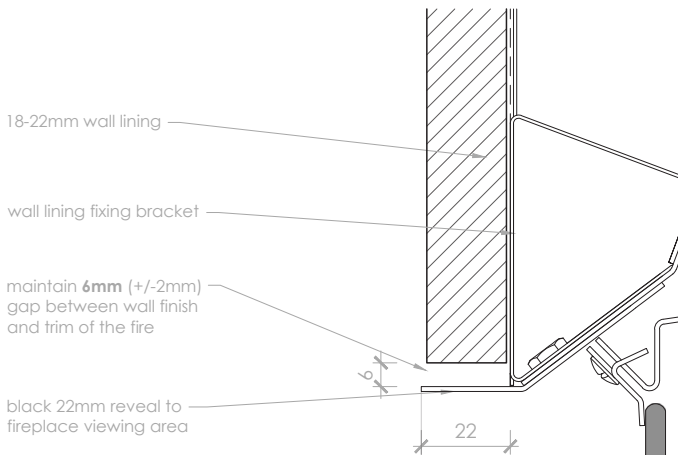

Note: a 20mm or less wall lining must be used when installing a KS1150 Peninsula 400 fireplace. A 10mm wall lining is recommended for ease of installation.

F7 Locating Wall Mount Cradle for Wireless Control

The appliance's remote contains the thermostat that will sense and communicate the room temperature back to the heater via radio frequency.

A wall mount cradle has been provided for the wireless control and, where possible, the control should be housed in this cradle.

The location of this cradle should be decided by taking the following factors into account:

- Simple and convenient access for the user
- Away from air flow and drafts through the room
- The parts of the room that people are likely to spend time
- Away from direct sun light
- A suitable distance away from the heater
- Ideally 1.2m to 1.5m from the floor

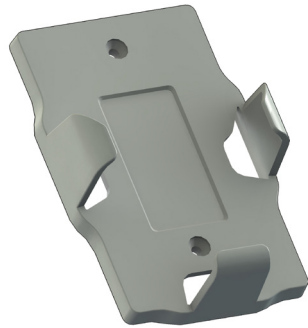

The radio frequency signal will go through some walls but for best results Escea suggest that the cradle position is less than 10 metres away from the heater.

The best height to locate the cradle off the ground is about chest height. This gives a good average room temperature and easy access for the user.

Please ensure that the cradle is screwed firmly onto the wall using the screws provided.

F8 Operating the Appliance

If you haven't done so already, insert the supplied "AA" size batteries, being careful of the polarity. "0:00" should now be showing on the remote display.

To turn the fire on, press the 'POWER' button once, and within a few seconds the appliance will begin its startup sequence.

NOTE: The appliance begins its startup with a 15 second pre-start purge, where the combustion fan runs on its own to clear the firebox before it tries to ignite. During the pre-purge the remote will alternately show the remotes "set" temperature and a rotating segment indicator to show that the fire is in start up mode and will try to ignite.

When the appliance has lit, set the room temperature by pressing the 'PLUS' or 'MINUS' buttons repeatedly until the display is showing the desired temperature. The remote will then revert back to the 'current' room temperature 30 seconds after making the change.

Run the appliance on full for an hour with the windows and doors open in the dwelling. This will ensure any running-in smells have the chance to dissipate.

The appliance is turned off by pressing the 'POWER' button once more. The remote will display the time only.

Run the appliance again and check the operation of the thermostat by increasing and reducing the set temperature. Check the Effect Only function and the Fan Boost functions work correctly.

For further operation instructions please refer to the User Guide.

F9 Normal Operating Sounds and Smells

Note: Each time the fire is lit from cold the glass may fog up with condensation. This is normal and the condensation will disappear within a few minutes once the glass heats up.

Sounds

It is possible that you will hear some sounds from your gas appliance. This is perfectly normal due to the fact that various types of materials are used within your appliance. Listed below are some examples. These are all normal operating sounds and should not be considered as defects in your appliance.

Fan:

Escea gas appliances use electric fans to push heated air into the room. It is not unusual for the fan to make a “whirring” sound when ON. This sound will increase or decrease in volume depending on the speed setting of your fan.

Gas Control Valve:

As the gas control valves turn ON and OFF, a dull clicking sound may be audible. This is the normal operation of a valve. When the fire is switched off after being run for a while, there may be popping and fluttering noises as the residual gas in the burners burns away. These are normal and are no cause for concern.

Unit Body/Firebox:

Different types and thicknesses of steel will expand and contract at different rates resulting in some “cracking” and “ticking” sounds being heard throughout the heating and cool down processes.

Smells

The first few times the unit is operated, the unit may release an odour and the flames will appear orange due to: the curing of the paint, the burning off of the starch in the gas logs and the oils in the metal. This is a temporary curing process which will disappear with use.

A deposit on the inside of the glass, caused by the starch in the logs, may appear as a build up after several uses. If this film is not removed, it will bake on and may become difficult to remove. When the glass is cold, remove it (see section E3 on page 24) and clean the inside with a non-abrasive cleaner.

DO NOT ATTEMPT TO CLEAN THE GLASS WHILE IT IS HOT.

UNDER NORMAL USE, NEVER OPERATE THE UNIT WITH THE GLASS REMOVED.

A

B

C

D

E

F

G

SERVICE

G Installation Checklist

Go through the following checklist to ensure you have installed the appliance correctly.

- Correctly sized cavity to suit your fireplace and flue configuration
- Correct clearances to combustibles
- An electrical isolating switch to the appliance, accessible after finished installation
- Correctly sized gas supply with a pressure test point, ensuring adequate supply with all other gas appliances in the dwelling running
- Gas type conversion process carried out if required
- A weather-tight installed horizontal or vertical powerflue terminal with clearance as specified by AS/NZS 5601.
- If chosen, reasonable access to the outside face of the horizontal powerflue wall terminal for maintenance purposes and flue attached to the rear of the horizontal powerflue wall terminal leading back to the appliance (and similar for vertical powerflue terminals)
- The electrical cable from the powerflue terminal attached correctly and run back to the appliance cavity in an electrically safe manner
- The appliance fixed to the cavity base
- The appliance plugged into a mains electricity supply
- All gas joints and pressure points leak tested with suitable leak detection solution and drop tests completed on gas pipework
- Fuel bed correctly installed
- Glass correctly fitted
- Operated the fire and verified that it lights reliably and safely
- Appliance functions checked, including thermostat operation, Effect and Fan Boost
- Data label marked up with correct gas type, and dated by installer if converted during installation
- Home-owner shown how to operate the appliance correctly
- Warranty card filled in with installer details and appliance serial number
- User Guide made available for end user
- Plumbing Industry Commission Compliance Certificate given to end user

A

B

C

D

E

F

G

SERVICE

IMPORTANT:

- This appliance must be serviced every 12 months.
- Any service operation should be carried out only by a suitably qualified and trained person.
- Gas and electricity supply **MUST** be isolated before any service operation is carried out on this appliance.
- This manual should be left with the appliance.
- Only use **Escea approved** spare parts.
- Escea Spare parts are available from an Escea Distributor or Retailer
- **DO NOT MODIFY THIS APPLIANCE.**

S1 Annual Service Procedure

- Isolate power and gas supply to fire.
- Remove glass and clean inside of glass.
- Remove fuel bed and brush off any soot.
- Clean electrode and pilot hood of any carbon build up and ensure correct gaps between electrode and pilot hood
- Remove burners and blow compressed air through the burner ports.
- Remove jets and clean injector hole with solvent.
- Vacuum any dust from the cavity that houses the fan and from the underside of the fire box around the valve and solenoids.
- Test all joints for gas tightness.
- Reassemble heater and check that operating pressure is correct.
- Check glass sealing tape and replace if necessary.
- Check to make sure that flue system is intact and not in any way blocked.
- Trial heater with several start/stop cycles. Trial fan-boost, effect only, and thermostat modes to ensure that all modes function correctly.

To access the product data plate, first remove the fireplace glass, any fuelbed media, the burners and the firebox base. The data plate is located underneath the controls tray (step 1 of section E5 on page 25).

A

B

C

D

E

F

G



SERVICE

S2 Error Codes

This gas fire has been designed to show error codes to help explain and identify any fault situation that occurs. These codes will appear on the wireless remote control in the form of a large letter “E” with a number beside it. Codes can normally be reset by turning the heater off then on again at the wall.

The following table shows what each code means and possible ways to rectify the situation. In the case of persistent or repeated shutdown errors, action must be taken immediately to find and repair the fault.

Note: An error code may not signify a fault/warranty issue; depending on the error code, it may signify that the remote batteries are dead or the LPG cylinder is empty. Refer to the section below and contact Escea if needed.

Error Code	Suggested action
 Electronics Over Temp	<p>The electronics have gone over temperature.</p> <ul style="list-style-type: none">• Check for excess lint and dust build-up on the PCB/Controller.• Ensure correct gaps are present around glass.• Room air fans may be slowed or stalled. Remove firebox, check that fans are plugged in, clean, and free turning. <p><i>Note: This error has a permanent lock out and will require the unit to be reset after the initial error (turning the power to the fire off “at the wall” then on again after a few seconds).</i></p>
 Flame Failure or Power Flue trip	<p>The fire has tried to light three times and failed.</p> <ul style="list-style-type: none">• Check gas supply and check other gas appliances to see if they are affected. If you have two separate LPG cylinders, switch over to the full bottle or contact your gas supplier. You may need to retry igniting the fire a few times after re-establishing gas supply.• Check correct gas pressure to the appliance with all other appliances running.• Check the electrode placement in relation to the pilot flame. Ensure it is well enveloped in flame as per the diagram in the installation instructions. Ensure no small coals have dropped onto the ignition electrodes between the burners.• Ensure the electrode is not contacting any metalwork including the burners and has the correct air gap.

A

B

C

D

E

F

G

SERVICE



Appliance Over
Temperature
Sensor Trip

- The bimetallic snap disk mounted on the exhaust collector box has tripped.
- Check that fans are plugged in, cleaned, and free turning - room air fans may be slowed or stalled.
 - Check the regulator - being set too high may result in excess heat build-up.
 - Check flues are securely connected at both ends - if the inlet flue is not connected the appliance may draw warm air from the cavity.
 - Check the jets



Valve Solenoid
Check Failure

- The valve solenoids have failed the pre-ignition test. A wire may have dislodged or the valve solenoid is faulty.
- Check that the connections to each solenoid are secure and in place. The connections on the ends of the wires may need to be tightened (e.g. with a pair of pliers) to ensure a robust connection to the valve terminal.
 - Disconnect and reconnect the firebox connectors ensuring they are firmly pushed into place.
 - One of the solenoids on the valve inside the fire may have failed. If this is the case, the valve will need to be replaced.



Remote Cannot
communicate with
fire

- The remote cannot communicate with the fire.
- Check if the fire is turned off "at the wall" i.e. a loss of power to the fire or the remote is outside of its effective radio frequency range (too far away from the fire). Typical remote range is 1m to 10m.
 - Ensure there is power to the fire by pressing the auxiliary on/off (red) button on the fire, then press the on/off button on the remote to clear the error.



Combustion Air
Flow Error

- Check whether the pressure switch is activating at startup (there is an orange indicator LED in the control tray). If not, check that the pressure switch electrical connection is correct.
- Check that the hoses are connected at both ends. Ensure the hoses are not kinked.
- Ensure the pressure switch is mounted vertically and the diaphragm is operational. The black hose should be connected to the low pressure port and the translucent to the high pressure port
- Check that both flues are securely connected at both ends to the appliance and the powerflue wall terminal and that the flue is not damaged
- Check that the fan inside the powerflue wall terminal is running during startup. This fan may need servicing if it is slowed or stalled.

S3 Cleaning the Fuel bed and Glass

ALWAYS USE GLOVES WHEN HANDLING THE GLASS.

Follow “Removing (and Replacing) the Glass” on page 24 to remove the glass. Place the glass carefully aside. Note that any soot on the glass can mark carpet and furnishings. Any standard ammonia-free glass cleaner may be used to clean the glass. Use a soft brush to clean the fuel bed media, being careful to replace it according to the instructions in “Gem/Crystalight or Coal Fuelbed Installation” on page 33, “Log Fuelbed Installation” on page 34, or “Woodland Fuelbed Installation” on page 35.

This is a service procedure that will need to be carried out whenever soot builds up on fuelbeds and/or inside of glass.

If soot build up becomes excessive or regular then one of the following actions may be required:

- Reset gas pressure, pressure may be too high;
- Reposition fuelbed, check with specific fuelbed instructions for details;
- Clear any blockage from primary aeration port of burner;
- Check flue tube is not damaged or disconnected.
- Check exhaust fan is operating and cowl is not blocked in any way.

S4 Checking Operating Pressure

See section E7 on page 27 of this manual.

S5 Replacing a Remote Control

If the wireless control becomes lost or damaged, a new one can be ordered from any Escea retail agent. When you have the new remote, the following procedure needs to be followed to “teach” the remote to only communicate with that fire.

1. Ensure the fire and remote are set to ‘OFF’ (only the time is displayed on the remote).

2. While the remote is in its ‘OFF’ mode with only the time showing on the display, press the MINUS, PLUS, and FAN BOOST buttons simultaneously (as shown right) until the characters “03” light up on the display. Release the buttons. The remote will count down and display “GO”. The screen will then display all characters and should be reading “00”. This will put the remote into test mode. *Note: if the digits start counting then the remote is already paired.*

3. Press and hold the MINUS button until the two large temperature digits reading “00” start to flash slowly. Release the MINUS button. The remote control is now ready to be linked to the fire.

4. Press and hold the auxiliary on/off button on the fireplace for a minimum of ten seconds or until the two large temperature digits start counting upwards from 00 to 99 repeatedly.

Note: Pressing the red auxiliary button on/off button will start the fire. Once the remote control is counting the fire can be turned off by pressing the red auxiliary button again.

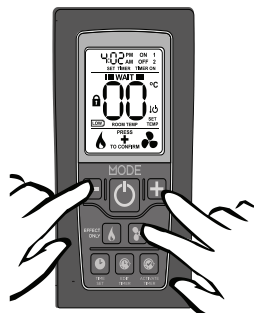

A

5. Press the large power button in the middle of the remote control to exit the test mode and return to normal operation. The remote should only be displaying the time. Check the fire will start using the remote control by pressing the large power button. Turn it off again using the remote control.

6. The fire is now linked to the remote control.

B

S6 Replacing the Burners

Remove all components of the fuelbed, taking care not to damage any of the fuelbed media.

Remove the 4 screws in the infill and lift from the fire box, by lifting one end up into the top corner and then out towards you. Take care not to scratch the firebox paint and lift out the burners (see section E4 on page 25).

C

S7 Serial Number

The serial number for the fire can be found in two places. The first is in the battery compartment of the wireless remote under the batteries. The second is on the data sticker on the chassis under the electronics tray.

D

S8 Removing or Cleaning Fan

As part of regular service procedure, it is recommended that the fan is removed for cleaning. Dust will build up on the fan rotor and in the cavity where the fan is located. This can be removed by the service person using a hearth brush and a vacuum cleaner.

ISOLATE THE POWER TO THE FIRE BEFORE COMMENCING THIS PROCEDURE.

Screw Locations:

E

F

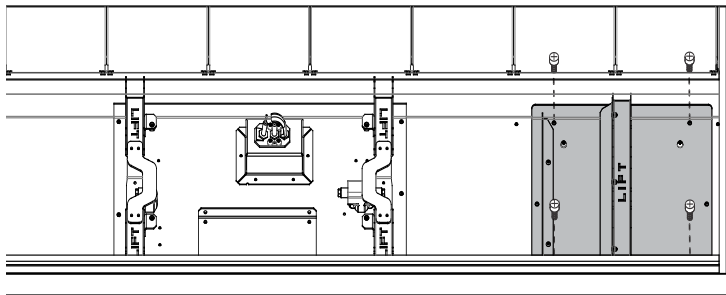

G

SERVICE

S9 Removing the Control Tray

ISOLATE THE POWER TO THE FIRE BEFORE THIS PROCEDURE.

Follow sections E3 on page 24 and E4 on page 25 to remove the glass, burners, and infill.

Remove the 8 screws on the controls tray (shown shaded in the diagram below).

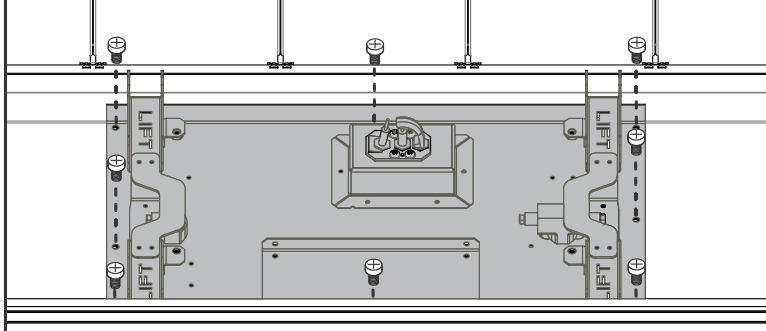

Remove the 'engine' by lifting up and to the right. This is still connected internally to the gas hose and power cables.

S10 Pressure Switch Removal

1. Follow the steps in section E3 on page 24 on both the front and back of the appliance to remove the glass. Follow the steps in section E4 on page 25 to remove the burners and infill. Carefully remove the floating ceiling by unscrewing the two screws hidden behind the negative detail.

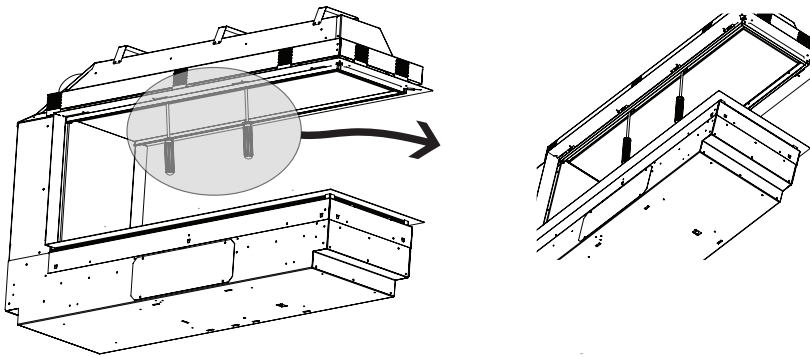

A

B

C

D

E

F

G

SERVICE

Once done, remove the 3 screws (circled below right) from the top side glass retainer (shown shaded below). Loosen the 3 screws in the two bottom brackets (circled below left). Carefully remove the glass panel from the firebox by tilting the top out first.

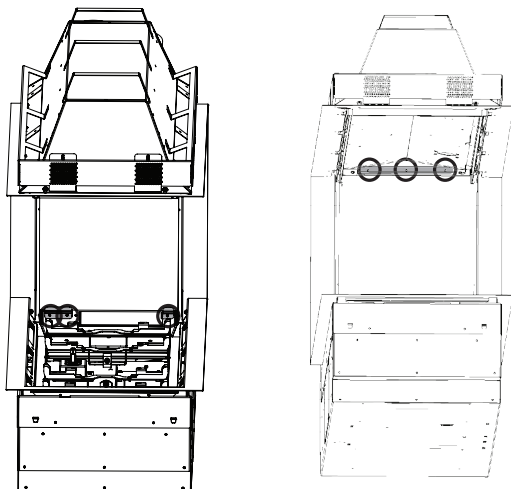

2. Remove the 10 screws (shown in the diagram below) in the access hatch and carefully remove from the firebox.

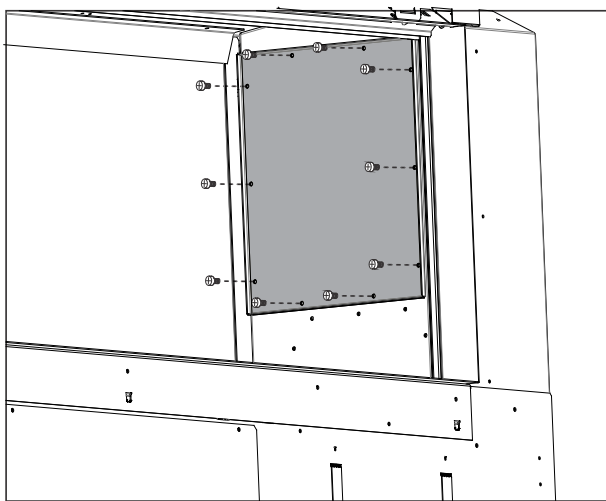

3. Remove the 2 silicone tubes. Disconnect the two wires from the pressure switch and remove the two screws on either side of the pressure switch to remove it from the bracket.

NOTE: Image shows MODE 850 (location is the same)

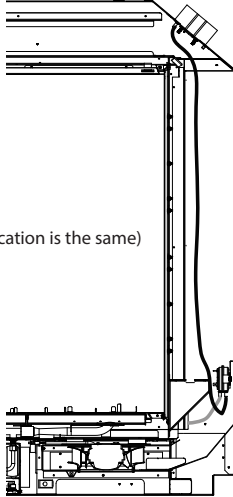

When reconnecting the pressure switch, be sure to connect the tubes as shown in the diagram below. The black tube should be connected between the grey side of the pressure switch and the low pressure port. The translucent tube should be connected between the black side of the pressure switch and the high pressure port.

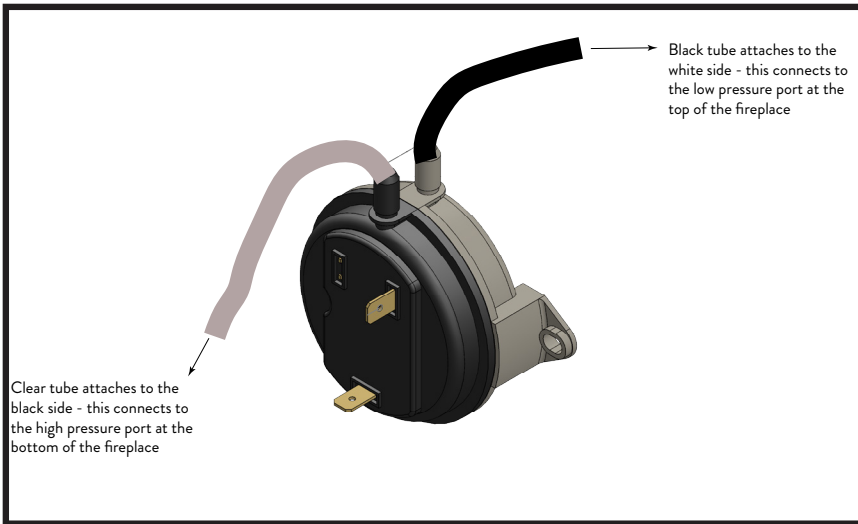

A

B

C

D

E

F

G

SERVICE

S11 Replacing the Thermal Cut Out (TCO)

WARNING - Ensure power is turned off before removing any TCO.

There is one thermal cutout attached to the exhaust manifold (120°C).

Exhaust TCO (120°C)

Access to this TCO can be made by following steps 1 to 2 from section S10 on page 47.

Reach in to the hatch and locate the TCO (circled in the diagram below). The TCO has two wires connected to the main body; remove these. Unscrew the TCO using your hand and remove from the firebox.

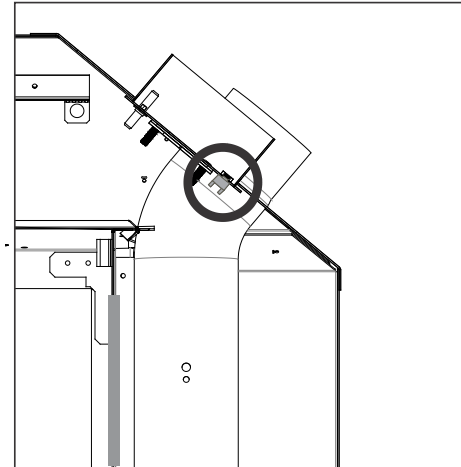

A

B

C

D

E

F

G

SERVICE

S12 Servicing the Horizontal/Universal Vertical Powerflue

Ensure the power to the powerflue is off by disconnecting the power to the appliance inside. If the appliance has been running, allow the powerflue to cool before attempting to service it.

Servicing a Horizontal Powerflue:

Undo the screws on the outside of the powerflue box and separate the two parts, giving you access to the fan inside.

Removing this plate gives complete access to the fan for servicing or replacement. Check that all the seals are still intact. Check that the fan electrical terminals, motor, and impeller are not corroded. Ensure there are no signs of leakage in or around the terminal.

When reassembling the powerflue, line up the round silicon grommets with the outlet tube of the fan and push the cowl back into place. Ensure all seals are still in place and replace all of the screws to hold the cowl in the correct position.

Servicing a Universal Vertical Powerflue:

If the UVP is internally installed remove the unit and replace the complete fan unit.

If the UVP is externally installed the cowl/fan unit (shown right) is to be completely replaced by removing it from the liner or flashing.

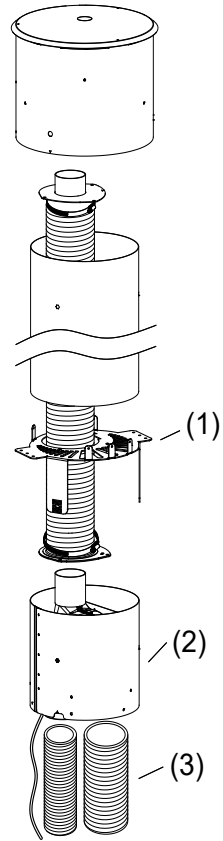
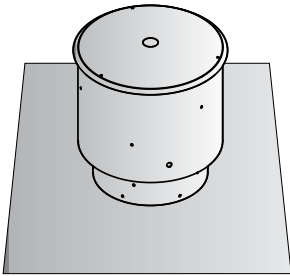

A

B

C

D

E

F

G

SERVICE

